



FOCUS 30



White Paper | June 2013

Spectra Precision® FOCUS® 30 Total Station

Spectra Precision, 10368 Westmoor Drive, Westminster, CO 80021, USA

© 2013, Trimble Navigation Limited. All rights reserved. Spectra Precision is a Division of Trimble Navigation Limited. Spectra Precision and the Spectra Precision logo are trademarks of Trimble Navigation Limited or its subsidiaries. GeoLock, Layout Pro, LockNGo, Ranger, StepDrive, and Survey Pro are unregistered trademarks of Trimble Navigation Limited. FOCUS is a trademark of Spectra Precision. Microsoft, Windows, and Windows Mobile are registered trademarks of Microsoft Corporation in the United States and/or other countries. The Bluetooth word mark and logos are owned by the Bluetooth SIG, Inc and any use of such marks by Trimble Navigation Limited is under license. All other trademarks are the property of their respective owners.

www.spectraprecision.com



Abstract

The Spectra Precision® FOCUS® 30 Total Station sets new standards for technology, design and ergonomic operation. Designed in Jena, Germany, the FOCUS 30 is offered in three versions: StepDrive™, LockNGo™, and Robotic. In combination with the Survey Pro™ and Layout Pro™ software applications, this solution effectively covers all the needs for surveying and layout construction measurement activities. StepDrive technology provides a fast and robust drive system, ensuring very precise manual sighting and fast tracking. The automatic LockNGo system, which detects, measures and tracks passive prism reflectors, is based on the latest camera technologies and image processing algorithms. Distance measurement uses the principle of phase shift measurement, both to prisms and to natural surfaces. Diametrically opposed readings eliminate circle eccentricity errors when measuring angles. Servomotor focusing is currently standard for high-end total stations. A wide-range tilt sensor allows large tilt positions to be displayed and the instrument to be leveled with ease. The instrument does not have to be switched off to change the battery, all applications and settings remain operational. As the lightest instrument of its type, the FOCUS 30 offers the user many features which once experienced are hard to manage without.

Torsten Kludas

Dr. Michael Vogel, Dr. Bernd Donath

Andreas Glimm, Hermann Göring,

Glenn Martin

Introduction

When it was launched in September 2009 at Intergeo in Karlsruhe, all commentators were in agreement: the FOCUS 30 sets new standards for total station design. The era of heavy cumbersome cases is over. The developers at Spectra Precision have done a great job in providing a top-class, small and light instrument containing the latest technology. It looks attractive and is ergonomic to operate.



Figure 1: FOCUS 30 design and ergonomic features

The FOCUS 30 not only incorporates established technologies such as its precision tilt sensor or distance meter based on the phase comparison method. New approaches have also been pursued such as the latest camera technologies to lock onto and track the target or the StepDrive drive system based on wear-resistant gear technology with a fast stepper motor drive. The excellent optical image quality continues Jena traditions in developing optical surveying instruments. The control unit with large 3.5" touchscreen color display and Windows® CE operating system is clearly designed and optimally adapted for use with the Survey Pro application software.

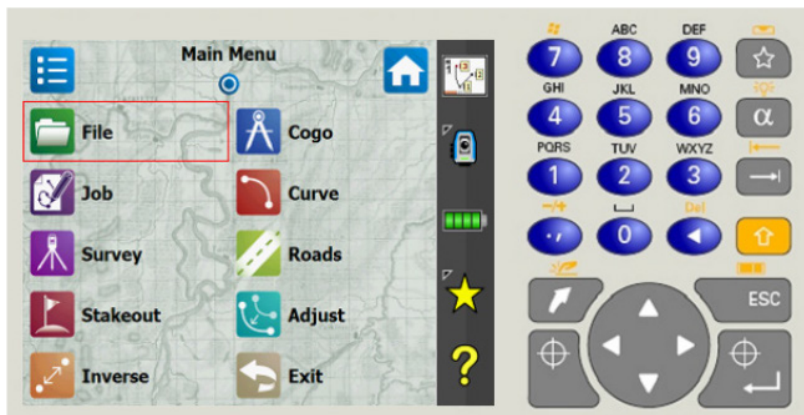

Figure 2: FOCUS 30 design and ergonomic features

The System

The FOCUS 30 design, from curved handgrip to control unit, offers many benefits. A stable instrument alidade has been developed which enables angular accuracies of 1" to be achieved. In addition the angle of view to the control unit is optimally designed to also ensure good readability in sunlight. Zenith measurements are possible, often used in combination with reflectorless distance measurement and optionally supported by the side-mounted motor focusing.

The telescope has 31x magnification and an aperture of 50mm, ensuring maximum range for all sensors working with laser light sources. The optical paths for distance meter, camera target sensor and laser pointer are coaxial. The track light is visible in the whole robotic range and is an important optical indicator when tracking and staking out. The distance meter operates according to the principle of phase shift measurement for both reflecting and weakly reflecting targets. The angle measurement system has diametrical readout of the coded glass circles and is specially calibrated to meet the demanding requirements of DIN/ISO and SIMT (China) standards. The tilt sensor is mounted exactly in the vertical axis to minimize its sensitivity to instrument rotation.

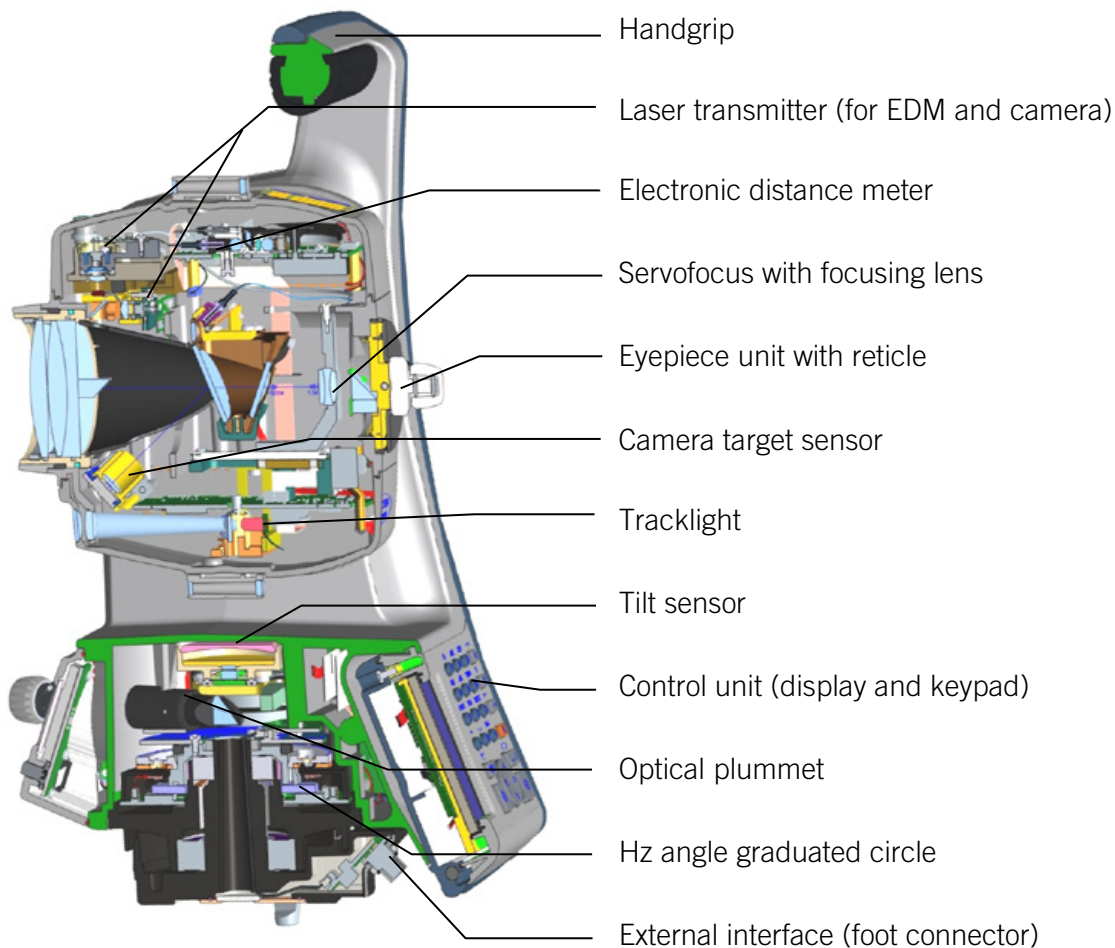

Figure 3: Optical and mechanical design of FOCUS 30

The operating controls for the motor drive are conveniently located on the right side. Intelligent software detects whether the user wants to move the telescope quickly or slowly and precisely onto the target. By using the F2 display and controls in the second face position, additional applications and information are available, such as settings for data communication, tilt display and measurement display, initiating measurement or changing telescope position. The F2 display is illuminated and is automatically heated in cold conditions.

The radio modem and battery are integrated into the side cover. The 5.0 Ah lithium-ion battery powers the instrument for 6 hours in normal operation. The instrument does not have to be switched off when replacing the battery as an internal support module maintains sufficient power for the change. Data communication in robotic mode uses 2.4 GHz SSFH radio (SSFH = Spread Spectrum Frequency Hopping). With this system data is transmitted on a frequency for only a very short time and it is possible to quickly switch between different channels. This means interference is significantly reduced and it is possible to work even when there is considerable radio communication in the area.

The optical plummet has a sliding focus from 0.5m to infinity with 2.4x magnification. The external interface connects the instrument to a PC through a USB port and is used for external power supply.



The FOCUS 30 robotic instrument can be remotely controlled using Spectra Precision data collectors. Windows Mobile® and Survey Pro, or Layout Pro, application software are installed to the data collector.

The Spectra Precision Ranger™ 3 data collector has integrated radio communication capability, so no cables are needed on the prism pole. It is the standard control unit for the robotic system.

The Ranger 3 has an integrated GPS module. This enables the GeoLock™ function to be used in the Survey Pro software for effective GPS target search.

The Ranger 3 data collector is very robust and meets IP67 dust and water ingress standards. The Ranger 3 data collector can also communicate with the instrument by USB cable or Bluetooth® wireless technology.

A passive 360° prism is used as a standard prism on the robotic pole.

Figure 4: Spectra Precision Ranger 3

For further information see: <http://www.spectraprecision.com/products/data-collectors/ranger-3/>



Figure 5: Cable free robotic prism pole with Spectra Precision Ranger 3 data collector

The FOCUS 30 is offered in three versions, StepDrive, LockNGo and Robotic:

FOCUS 30	StepDrive	LockNGo	Robotic
Servomotor	✓	✓	✓
EDM	✓	✓	✓
Track light	✓	✓	✓
Laser pointer	✓	✓	✓
Camera target sensor		✓	✓
Radio Communication			✓

Table 1: The FOCUS 30 instrument versions

Each version is available in all selectable accuracy classes.

Angle and Distance Measurement

The Angle Measurement System

The FOCUS 30 measures angles using coded glass circles and provides absolute angle values. The glass circle is coded with two tracks: an absolute coarse code and an incremental fine code. The angles are scanned by two diametrically opposed Complementary Metal–Oxide–Semiconductor (CMOS) sensors. This eliminates circle eccentricity errors and results in more accurate angle measurements. The angle measurement assemblies for Horizontal (Hz) angles and Vertical (V) angles have identical design. The only difference is in which component moves and which is fixed. In the Hz angle system, the glass circle is mounted in a fixed position while the scanning units on the Hz angle measurement board with rotating alidade are positioned over the graduated circle. In the V angle measurement system it is the other way round. Here the V angle measurement board is fixed while the glass circle with telescope rotates about the trunnion axis. Each graduated circle has a cover to provide additional protection from dirt or dust.

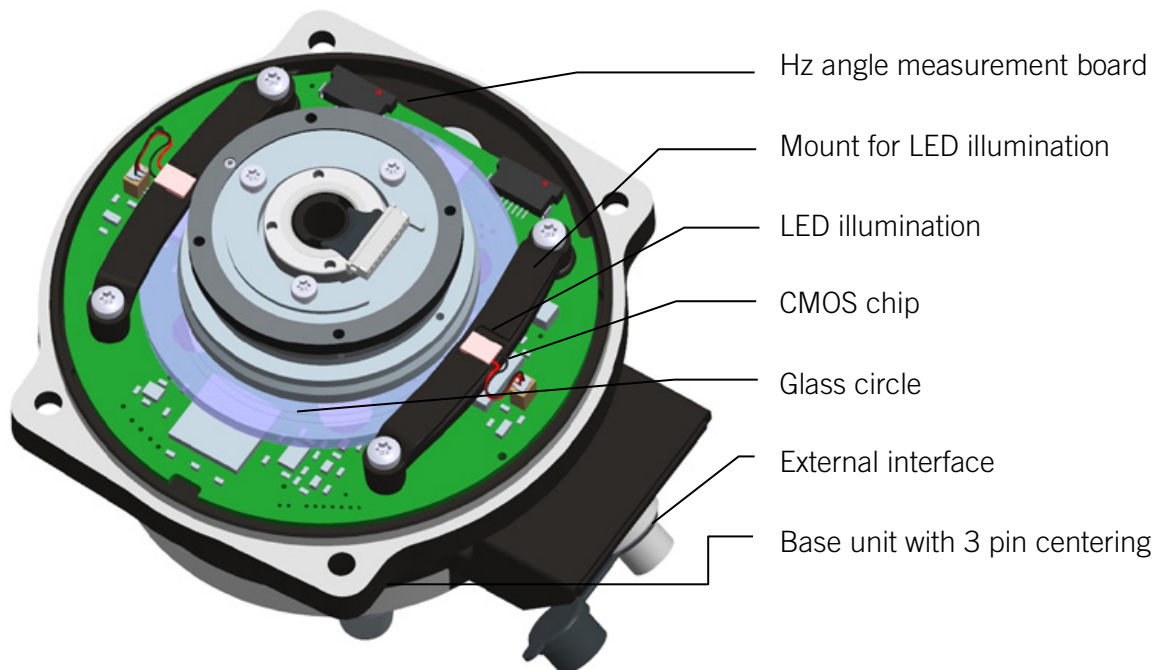

Figure 6: Base unit with horizontal angle measurement system

The resolution of the angle measurement system is 0.3" (0.1 mgon). The maximum angle scan rate is 200 Hz, an optimal value for fast tracking. This system enables accuracies of up to 1" to be achieved (according to ISO 17123-3).

Through fully automatic determination of horizontal and vertical collimation errors and any trunnion axis inclination and eccentricity, the FOCUS 30 provides inbuilt corrections for direction measurement. The automatic calibration process also simultaneously measures and stores any correction required to compensate for the movement of the

focusing lens. This allows for highly precise measurements on only one face, reducing the need for a second face measurement.

Tilt Measurement

To correct vertical axis tilt, the FOCUS 30 uses a dual axis compensator mounted exactly in the vertical axis. This minimizes its sensitivity to instrument acceleration. Silicone oil is enclosed in a cuvette with its surface perpendicular to gravity. A LED transmits a light beam which is reflected back to the light source from the surface after passing through an optical system and focusing. A CMOS sensor next to the light source scans the point of light in two image coordinates. This enables both tilt components to be recorded and corrected.

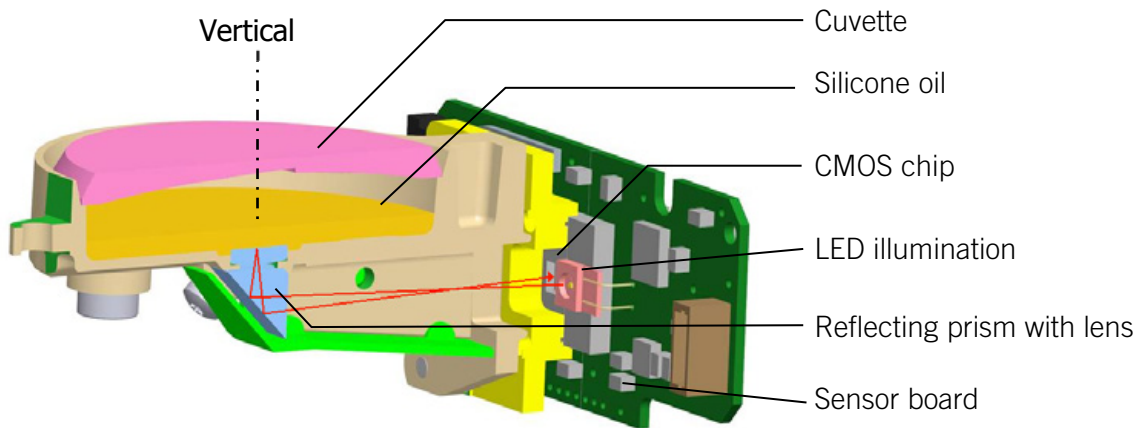

Figure 7: FOCUS 30 liquid compensator for precise tilt determination

The illumination and receiver are fixed on a board next to each other, giving the system high stability. The working range in precision mode of $\pm 6'$ is very large. With a resolution of 0.1 mgon in this range, very high accuracy can be achieved. In addition an extended range of approximately $\pm 37'$ is available, where the compensator provides lower accuracy but still reliable measurements.

The FOCUS 30 incorporates an additional tilt sensor using a working range of $\pm 3^\circ$ to replace the function of a manual bubble level.



This sensor is a 3D acceleration sensor based on MEMS technology (MEMS = micro-electro-mechanical system), which can measure any tilt in 3D space. This allows tilt values to be displayed with the F2 display for coarse leveling of the instrument immediately after switching on the instrument. After reaching the working range of the precise compensator, the precise compensator's values are automatically used.

Figure 8: Size comparison of an MEMS acceleration sensor

Distance Measurement

The EDM (EDM = Electronic Distance Meter) operates according to the phase comparison principle using digital phase measurement, one of the most accurate methods in electro-optical distance measurement. A laser transmits a coaxial, intensity-modulated light beam which is reflected from the target and detected by a receiver. The distance is calculated from the phase shift $\Delta\lambda$ between transmitted and received light. The measurement is confirmed by using several scale frequencies derived from a temperature compensated quartz oscillator (TCXO). The transmitter emits modulated laser light with a wavelength $\lambda = 660$ nm, which is in the red, visible range. The modulation frequency is $f = 400$ MHz with a fine scale of 375.2 mm.

The measurement principle (simplified) based on determining the phase shift $\Delta\lambda$, which is added to $n\lambda$ multiples of the wavelength is as follows:

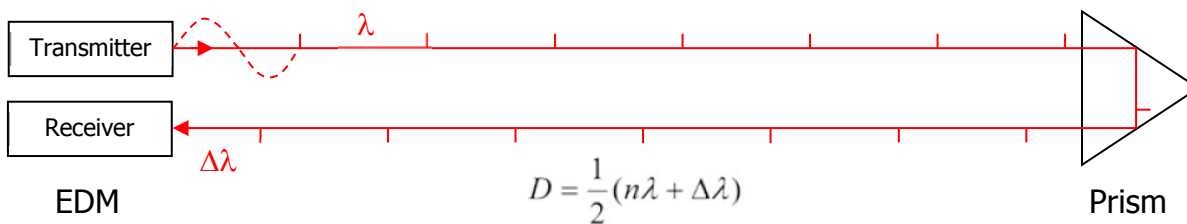

Figure 9: Principle of distance measurement using the phase comparison method

The EDM can measure to reflecting targets such as prisms or foil reflectors as well as very weakly reflecting natural surfaces (“reflectorless”). In reflectorless mode the emitted laser radiation corresponds to laser protection Class 3R (power < 5 mW). The appropriate safety measures must be observed. In prism mode the EDM operates in eyesafe laser protection Class 1 (power < 0.39 mW).

The accuracy achieved to prisms is 2 mm + 2 ppm (according to ISO 17123-4). In reflectorless distance measurement, accuracies of 3 mm + 2 ppm are achieved.

The measurement time to prisms is from 2 to 3 seconds, to reflectorless targets it is from 3 to 15 seconds, depending on distance and conditions.

The range of distance measurements depends on atmospheric conditions, ambient light and the reflecting properties of the target. In good conditions a range of 4000 m to a 50mm prism can be achieved. For reflectorless measurement in very good conditions, a range of up to 800 m can be achieved, but range is reduced in very adverse conditions. However, it is not only visibility which determines whether conditions are good or bad.

Good conditions: good visibility > 20 km, shadows or twilight (low ambient light), little heat shimmer, bright object, prism clean

Bad conditions: bad visibility < 5 km, strong sunlight on the target (strong ambient light), strong heat shimmer, dark object, prism dirty or fogged

The shortest distance to achieve the specified accuracy for prism measurement and reflectorless measurement is 1.5 m.

The spot size of the EDM transmitter is 0.4 mrad x 0.3 mrad (Hz x V), which for a distance of 100 m gives a spot of 4 cm x 3 cm. The transmitter is also used as a laser pointer (without frequency modulation) of laser protection Class 3R.

Checking against the standard length is done by measuring nominal distances and determining the required EDM zero correction (addition constants). These nominal distances are measured with very accurate reference devices, which are regularly calibrated using an interferometric linear measuring system at the German Metrology Institute (Physikalisch-Technische Bundesanstalt - PTB) in Brunswick.

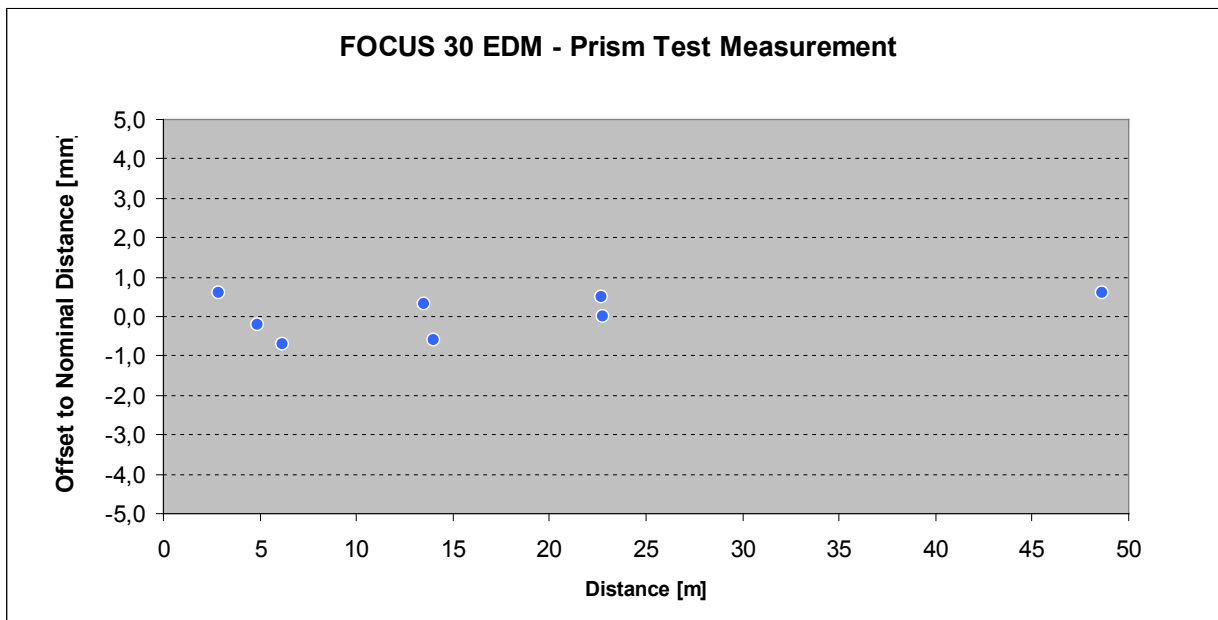

Figure 10: Comparison measurement of test distances, FOCUS 30 with 2mm + 2ppm accuracy

The standard atmosphere for which the FOCUS 30 EDM has 0 ppm atmospheric correction, is defined as a temperature of 20.0°C, atmospheric pressure of 1013.25 hPa and relative air humidity of 60%. The instrument has an internal temperature sensor which can be used to make atmospheric corrections. The air pressure can be manually entered into the application software. The relative humidity is set to the standard of 60%. The overall range of atmospheric corrections is from -150 ppm to +160 ppm.

StepDrive Technology

The StepDrive in the FOCUS 30 is a two-part drive system with coarse and fine functions based on stepper motor technology. The coarse drive is a single-stage gear with a drive pinion on the shaft of the motor directly engaging the combined driven gears. This is sufficient to provide very quick reaction and positioning of the instrument but not precise enough for exact targeting. A fine drive was therefore developed which moves the entire coarse drive unit laterally with adequate resolution by means of a lever arm. The rotational axis of the lever arm is identical to the motor axis of the coarse drive. The system is controlled by the drive controller microprocessor, which is the central control unit of the drive system.

To optimize power transmission, the coarse drive motor axis is fixed to the fine drive with a mechanical clamp. To achieve this a leaf spring is pulled against a disk by a solenoid. To make the fine drive “continuous”, the drive controller produces a return movement by temporarily releasing the clamp to the coarse drive.

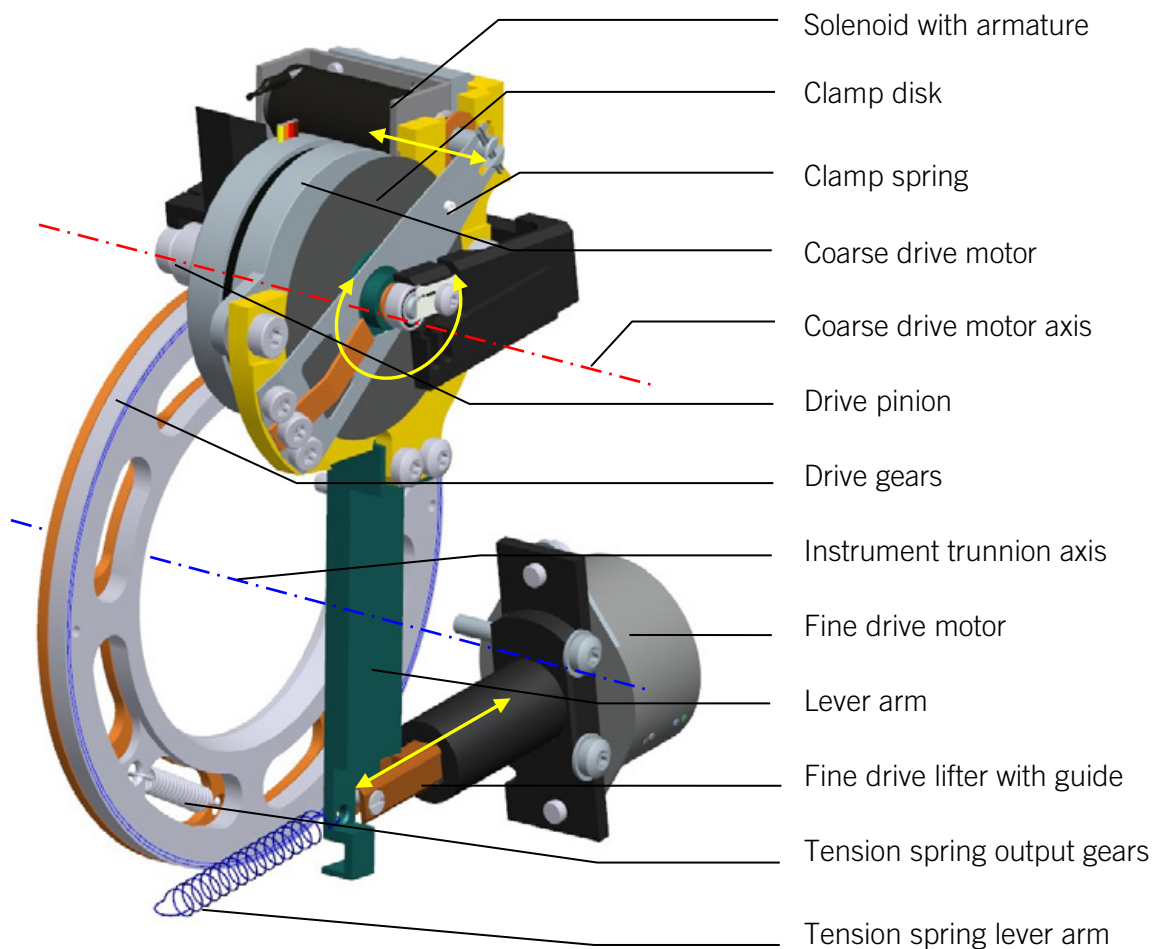

Figure 11: Vertical StepDrive system

When the FOCUS 30 is in an idle state, the coarse drive is always held clamped by the bistable solenoid and fine mode is activated. The coarse drive motor is switched off, saving power.

The system is designed so the telescope and alidade can still be manually released and turned, since the drive controller monitors whether force is applied and releases the clamp as necessary. The user can therefore quickly and easily point the telescope at the target.

The rotational speed when operating the side knobs determines whether the system switches between coarse or fine adjustment. If the movement is fast the clamp is released and the drive switches to coarse movement. If the movement is slow the coarse drive is clamped and fine mode takes over.

Software activated motor positioning of the telescope on a target, or a shift in telescope position, is always a combination of coarse and fine movements of the horizontal and vertical drive units, and is controlled by the drive controller. At the end of this movement the horizontal and vertical fine drives take over precise positioning. The maximum speed achieved in coarse movement is 90°/sec.

In robotic tracking mode only the coarse drive is used and when making a measurement it corrects the measured angle according to the measured camera offset of the prism center to the reference (crosshair).

The angular displacement per step of the coarse drive motor is 0.9°. Micro-step positioning by the drive controller enables a smallest increment of 23" to be achieved. The coarse drive is then able to move within the EDM beam of 83" for tracking and can perform EDM distance tracking.

The angular displacement per step of the fine drive motor is 7.5°. Taking account of the overall gear ratio (lever arm, gearing) of the fine and coarse drive, it is possible to achieve a smallest increment of 0.3" in microstep operation of the fine drive. This enables positioning and targeting to be accurate to within a second.

By fixing the telescope and alidade with a mechanical clamp in the drive system the FOCUS 30 has high internal stability to help avoid instrument vibrations independent from instrument mounting and stationing. It also means that the telescope remains steadily aligned on the target and can withstand external influences such as wind or pressing of the keys on the control unit.

The StepDrive designs for horizontal and vertical drive are almost identical.

LockNGo Technology

The FOCUS 30 LockNGo function for automatic target locking, measuring and tracking is based on the latest camera technologies with intelligent image processing. LockNGo can therefore be used with all passive reflecting prisms.

This system is also subdivided into a transmitter and receiver. A 850 nm wavelength laser light source is used as transmitter and emits an invisible laser beam of laser protection Class 1. A CMOS sensor with field of view $2.1^\circ \times 1.4^\circ$ (Hz x V) is used as receiver.

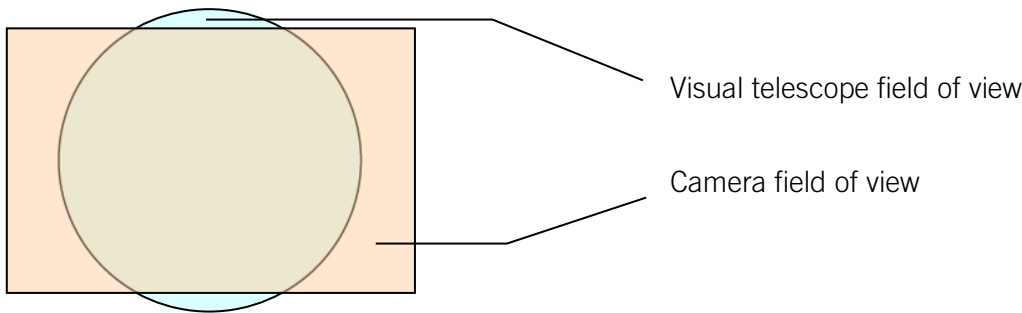

Figure 12: Camera and visual field of view

Due to the CMOS chip size the camera field of view in the horizontal direction is larger than the visual telescope field of view. This is an advantage as seeking or tracking the prism in a horizontal direction must cover a larger area.

The speed of the drive system is not the sole decisive factor for robotic tracking. The measurement frequency for signal processing of the camera target sensor is equally important. In the LockNGo tracking mode up to 109 images per second are processed by a very fast digital signal processor. This means that there is information 109 times a second about which direction the target is moving in.

The instrument rotational speed depends on the distance. The maximum value of 99 gon/sec is reached with an object speed of 7.8 m/sec at 5 m distance. The FOCUS 30 motor system therefore has sufficient speed. The angle measurement system with 200 Hz clock rate is always able to keep up with the control circuit.

Range	Object moves at 1 m/sec = 3.6 km/h (normal walking)	Object moves at 7.8 m/sec = 28 km/h (extremely fast)
100m	0.64 gon/sec	5 gon/sec
10m	6.4 gon/sec	50 gon/sec
5m	12.7 gon/sec	99 gon/sec

Table 2: Required angular velocity for different distances

The question is whether the camera target sensor can permanently track the object in the field of view at this speed without losing it. Since the object is always placed centrally when tracking, we can consider just the half field of view.

Parameter	Value
Maximum clock rate	109 Hz
Resolution at max. 7.8 m/sec	72 mm
Half field of view (angle)	1.1°
Half field of view @ 100 m	1.92 m
Half field of view @ 10 m	0.19 m
Half field of view @ 5 m	0.096 m

Table 3: LockNGo parameters

In the next figure it can be clearly seen that with these values and a maximum speed of 7.8 m/sec a new position can be determined in the half field of view even at 5 m distance, and for a distance of 10 m two new positions can be determined. If one then considers reaction times and accelerations it is realistic to say that the FOCUS 30 can track a prism with a speed of around 7 m/sec at 10 m distance..

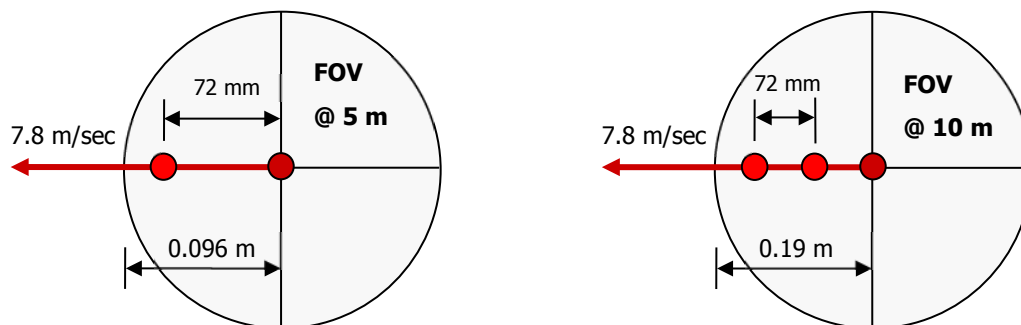

Figure 13: Detected positions in half field of view at distances of 5m and 10m

Conclusion: A combination of StepDrive and LockNGo technology enables a prism to be tracked very accurately and almost instantaneously.

A further quality criterion is how robustly a target can be tracked: whether it is susceptible to cross interference (for example, safety vests) or what happens if another prism comes into the field of view. When the FOCUS 30 camera target sensor is locked on a prism, intelligent programming ensures that other reflections in the camera field of view are ignored.

When a target is found during a search, it is checked several times to confirm whether it is a prism. This means that, for example, strong sun reflections or other bright light sources such as vehicle headlights are eliminated from the outset.

When doing survey work it is often necessary to wear reflective safety vests. Particularly at close range they can cause measurement errors in target acquisition sensors or may even be tracked as a target by the instrument.

FOCUS 30 LockNGo				Other total station			
Without safety vest		With moving safety vest in background		Without safety vest		With moving safety vest in background	
Hz [gon]	V [gon]	Hz [gon]	V [gon]	Hz [gon]	V [gon]	Hz [gon]	V [gon]
70.1549	100.1668	70.1551	100.1670	200.7445	99.9068	200.7451	99.9074
70.1551	100.1668	70.1550	100.1670	200.7445	99.9069	200.7451	99.9084
70.1550	100.1669	70.1550	100.1670	200.7445	99.9070	200.7448	99.9097
70.1550	100.1668	70.1549	100.1670	200.7445	99.9071	200.7443	99.9092
70.1551	100.1668	70.1550	100.1669	200.7445	99.9070	200.7436	99.9091
70.1549	100.1669	70.1550	100.1669	200.7446	99.9070	200.7429	99.9067
70.1549	100.1669	70.1551	100.1670	200.7445	99.9070	200.7427	99.9071
70.1550	100.1669	70.1550	100.1670	200.7445	99.9070	200.7431	99.9092
70.1550	100.1670	70.1551	100.1669	200.7445	99.9070	200.7440	99.9097
70.1550	100.1669	70.1551	100.1670	200.7444	99.9070	200.7437	99.9086
$\sigma = 0.7^{cc}$	$\sigma = 0.7^{cc}$	$\sigma = 0.7^{cc}$	$\sigma = 0.5^{cc}$	$\sigma = 0.5^{cc}$	$\sigma = 0.8^{cc}$	$\sigma = 8.9^{cc}$	$\sigma = 10.9^{cc}$

Table 4: Effect of a safety vest on measurement result (standard deviation σ)

Table 4 shows the effect of a safety vest with horizontal reflective stripes moving randomly at a distance of 14 m behind the prism, compared to another instrument with automatic target lock. The high precision of LockNGo technology is evident from the results in the table.

In LockNGo mode the instrument is immediately locked to the prism and is automatically in tracking mode. If a measurement is initiated, then the deviation (dHz, dV) to prism center is determined by the camera and applied to the measured Hz and V directions. The position of the crosshairs on the camera is defined by a reference pixel, which can be determined by the user in the application software.

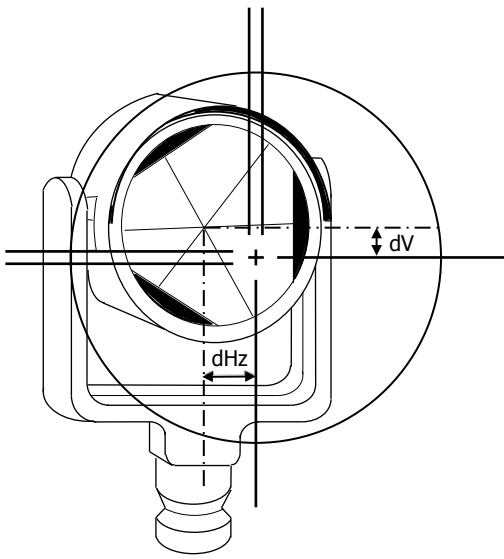

Figure 14: LockNGo deviation

This measurement method significantly speeds up the measurement process. Instead of the time-consuming procedure of aiming to the prism center, here only a fraction of the time is needed. Several camera measurements are made in less than 0.5 sec and averaged. This considerably increases measurement accuracy, particularly if there is air shimmer.

If the user wishes to visually confirm whether the prism center has really been measured, it is just necessary to deactivate LockNGo mode. The instrument then automatically moves to the actual prism center position measured using LockNGo with application of all corrections.

Software Development Tools

The FOCUS 30 can be used for numerous tasks other than those supported with Survey Pro, or Layout Pro.

A Software Development Toolkit (SDK) can be requested and developers can write their own solutions.

The SDK offers rich, Microsoft .NET Development capabilities for controlling the FOCUS 30 as a sensor for collecting, tracking, monitoring, or checking positional and measurement information.

FOCUS 30 – “Simply Powerful”

The FOCUS 30 from Spectra Precision provides the user with a high accuracy measuring instrument for performing everyday surveying tasks. It is simple to operate and reliable. The latest technologies and outstanding operating convenience make this instrument a world class electro-optical total station.

The FOCUS 30 is Spectra Precision’s flagship product in the FOCUS family and is enhanced by a wide range of accessories and data processing software. Further information at <http://www.spectraprecision.com/>.



Figure 15: FOCUS 30 control unit with Survey Pro application software

Literature

Dr. Martin Köhler, Die Trimble S6 Totalstation - Neue Technologien in der Tachymeterentwicklung, Lecture Trimble Express 2005

Glenn Martin, *Trimble Data Collectors - Technology and Choice for the Integrated Surveying Solution*, White Paper, Trimble Navigation Ltd. 2005 http://www.trimble.com/survey_wp_totalstations.asp

Acknowledgements

Special thanks to the FOCUS 30 development team of Trimble Jena GmbH, the ART-KON-TOR Jena industrial design team, the Survey Pro and Layout Pro development team of Trimble Corvallis, OR, USA, the marketing team of Spectra Precision Division in Westminster, CO, USA.